

XDR-F1HD

SERVICE MANUAL

US Model

Ver. 1.0 2008.01



HD Radio Broadcasting was approved by the Federal Communications Commission in October 2002 as the system for digital AM and FM broadcasting in the U.S.

HD Radio technology features include:

- Static-free, clear radio reception.
- FM Multicasting – the ability to broadcast multiple program streams over a single FM frequency.
- A variety of “data services,” including text-based information – artist name, song title, etc. scrolled across your receiver display.
- Digital broadcasts in the same frequencies as analog broadcasts; listeners do not need to learn a new station number and today’s stations remain at their current place on the dial.

HD Radio technology is developed and licensed by iBiquity Digital Corporation and supported by the leaders of the broadcasting, consumer electronics and automotive industries.

HD Radio™ Technology Manufactured Under License From iBiquity Digital Corp. U.S. and Foreign Patents. HD Radio™ and the HD Radio logo are proprietary trademarks of iBiquity Digital Corp.

SPECIFICATIONS

Time display	12-hour system
Frequency range	FM: 87.5 – 108 MHz AM: 530 – 1,710 kHz
Audio output	Output level 0.7 Vrms at 47 kΩ Recommended load impedance over 10 kΩ
Antenna terminal	75 Ω antenna terminal for FM Antenna terminal for AM
Power requirements	120 V AC, 60 Hz
Dimensions	Approx. 180 × 60 × 160 mm (w/h/d) (7 1/8 × 2 3/8 × 6 3/8 inches) not incl. projecting parts and controls
Mass	Approx. 1.1 kg (2 lb 6.8 oz)
Supplied accessories	Remote commander (1) FM dipole antenna (1) AM loop antenna (1)

Design and specifications are subject to change without notice.

FM/AM DIGITAL TUNER

9-887-972-01
2008A04-1
© 2008.01

Sony Corporation
Audio Business Group
Published by Sony Techno Create Corporation

SONY®

SAFETY CHECK-OUT

After correcting the original service problem, perform the following safety check before releasing the set to the customer: Check the antenna terminals, metal trim, “metallized” knobs, screws, and all other exposed metal parts for AC leakage. Check leakage as described below.

LEAKAGE TEST

The AC leakage from any exposed metal part to earth ground and from all exposed metal parts to any exposed metal part having a return to chassis, must not exceed 0.5 mA (500 microamperes.). Leakage current can be measured by any one of three methods.

1. A commercial leakage tester, such as the Simpson 229 or RCA WT-540A. Follow the manufacturers’ instructions to use these instruments.
2. A battery-operated AC milliammeter. The Data Precision 245 digital multimeter is suitable for this job.
3. Measuring the voltage drop across a resistor by means of a VOM or battery-operated AC voltmeter. The “limit” indication is 0.75 V, so analog meters must have an accurate low-voltage scale. The Simpson 250 and Sanwa SH-63Trd are examples of a passive VOM that is suitable. Nearly all battery operated digital multimeters that have a 2 V AC range are suitable. (See Fig. A)

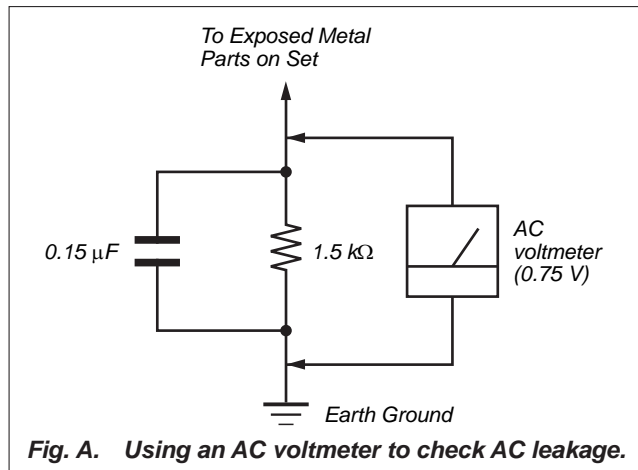

Notes on chip component replacement

- Never reuse a disconnected chip component.
- Notice that the minus side of a tantalum capacitor may be damaged by heat.

UNLEADED SOLDER

Boards requiring use of unleaded solder are printed with the lead-free mark (LF) indicating the solder contains no lead.

(Caution: Some printed circuit boards may not come printed with the lead free mark due to their particular size)

LF : LEAD FREE MARK

Unleaded solder has the following characteristics.

- Unleaded solder melts at a temperature about 40 °C higher than ordinary solder.
Ordinary soldering irons can be used but the iron tip has to be applied to the solder joint for a slightly longer time. Soldering irons using a temperature regulator should be set to about 350 °C.
Caution: The printed pattern (copper foil) may peel away if the heated tip is applied for too long, so be careful!
- Strong viscosity
Unleaded solder is more viscous (sticky, less prone to flow) than ordinary solder so use caution not to let solder bridges occur such as on IC pins, etc.
- Usable with ordinary solder
It is best to use only unleaded solder but unleaded solder may also be added to ordinary solder.

TABLE OF CONTENTS

1. GENERAL	3
2. DISASSEMBLY	
2-1. Cabinet Upper Assy	6
2-2. KEY Board.....	7
2-3. MICON Board Assy.....	7
2-4. MAIN Board.....	8
2-5. POWER Board.....	8
3. DIAGRAMS	
3-1. Block Diagram.....	11
3-2. Printed Wiring Board –Main Section–.....	12
3-3. Printed Wiring Board –Power Section–.....	13
3-4. Schematic Diagram –Main/Power Section–	14
3-5. Printed Wiring Board –Micon Section–.....	15
3-6. Schematic Diagram –Micon Section–	16
4. EXPLODED VIEWS	
4-1. Cabinet Upper Section	20
4-2. Cabinet Lower Section.....	21
4-3. MICON Board Section	22
5. ELECTRICAL PARTS LIST	23

SAFETY-RELATED COMPONENT WARNING!

COMPONENTS IDENTIFIED BY MARK \triangle OR DOTTED LINE WITH MARK \triangle ON THE SCHEMATIC DIAGRAMS AND IN THE PARTS LIST ARE CRITICAL TO SAFE OPERATION. REPLACE THESE COMPONENTS WITH SONY PARTS WHOSE PART NUMBERS APPEAR AS SHOWN IN THIS MANUAL OR IN SUPPLEMENTS PUBLISHED BY SONY.

SECTION 1 GENERAL

This section is extracted from instruction manual.

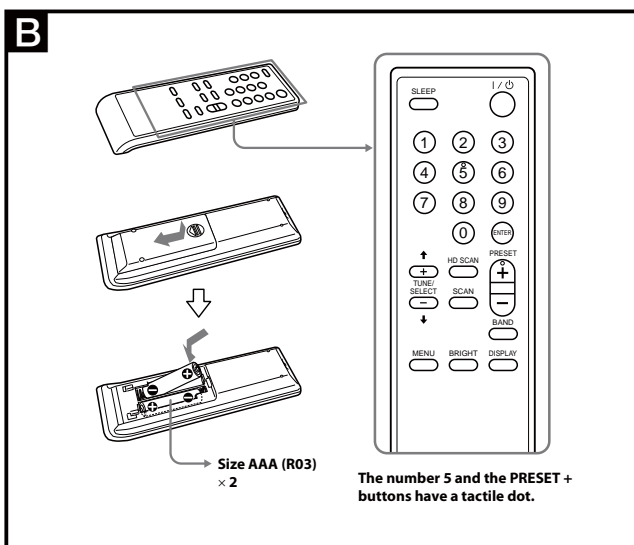
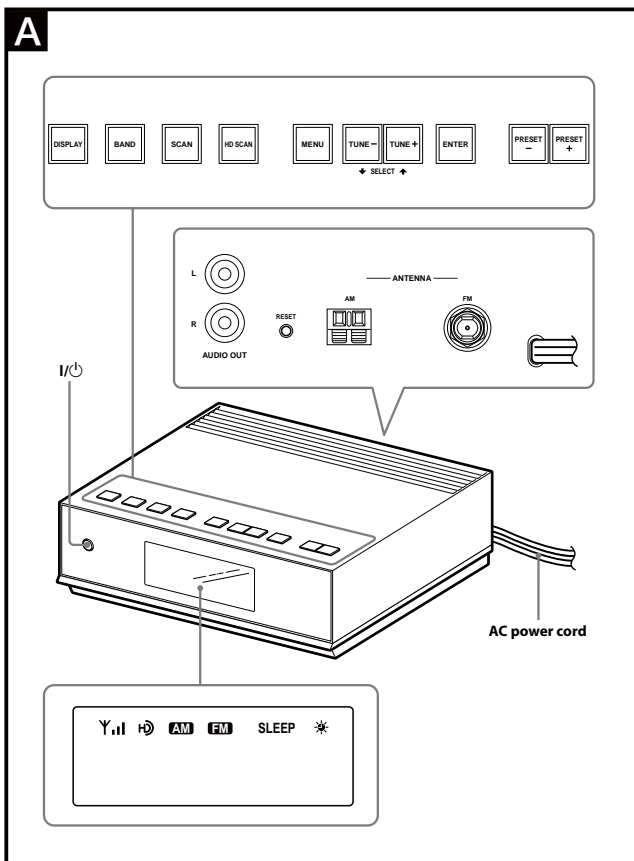

Preparing the remote commander

Installing the batteries into the remote commander (See Fig. B)
Insert two size AAA (R03) batteries (not supplied).

When to replace the batteries

With normal use, the batteries should last for about six months. When the remote commander no longer operates the unit, replace all the batteries with new ones.

Notes

- Do not charge dry batteries.
- When you are not going to use the remote commander for a long time, remove the batteries to avoid any damage caused by leakage and corrosion.

Setting the clock

- 1 Plug in the unit.
The display will flash "AM 12:00."
- 2 Press **MENU** to show the menu display.



- 3 Press **SELECT** ↑ or ↓ to select "TIME SET" then press **ENTER**.
The hour will start to flash in the display.

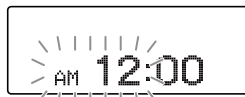

- 4 Press **SELECT** ↑ or ↓ until current hour appears in the display, then press **ENTER**.
The hour is set and the minutes start to flash.
- 5 Repeat step 4 to set the minute.

Note

If you do not set the menu within 65 seconds, the setting mode is canceled.

To change the display to the daylight saving time (summer time) indication

- 1 Press **MENU** to show the menu display.
- 2 Press **SELECT** ↑ or ↓ to select "DST," then press **ENTER**.
- 3 Press **SELECT** ↑ or ↓ to select "ON," then press **ENTER**.
"*" appears and the time indication changes to summer time.

To deactivate the DST function, select "OFF" in step 3.

Playing the radio

-Manual tuning

- 1 Press **I/O** to turn on the radio.
- 2 Press **BAND** to select the band AM or FM.
- 3 Press **TUNE +** or **-** to tune in to a desired frequency.

Note

The frequency cannot be input with the number buttons of the remote commander.

-Preset tuning

You can preset 20 stations each for AM and FM.

Presetting a station

- 1 Follow steps 1 to 3 in "Manual tuning" to tune the frequency you wish to preset.
- 2 Press and hold **ENTER** for a few seconds.
The display changes as follow:



- 3 Press **PRESET +** or **-** to select the preset number, then press **ENTER**.
The frequency is stored in the selected preset number.

To preset another station, repeat these steps.

Note

If you try to store another station in the same preset number, the previously stored station will be replaced.

Tuning in to a station

- 1 Press **I/O** to turn on the radio.
- 2 Press **BAND** to select the band AM or FM.
- 3 Press **PRESET +** or **-** to select the desired preset number.

Tip

The preset can be selected by pressing the number button of the remote commander. Press **ENTER** after the preset number is selected.

-Scan tuning

The unit will automatically scan the selected band. In HD scan, HD Radio stations are scanned.

- 1 Press **I/O** to turn on the radio.
- 2 Press **BAND** to select the band AM or FM.
- 3 Press **SCAN** or **HD SCAN** on the unit or remote commander.
Scanning of the selected band starts. When a station is received, scanning pauses for 3 seconds and then continues.
- 4 When the unit tunes in to the desired station, do any of the following operations to stop scanning.
 - Press **ENTER** on the unit or remote commander.
 - Press **SCAN** or **HD SCAN**.
- 5 If necessary, press **TUNE +** or **-** to tune in to the station more precisely.

Changing the display mode and settings

To change the display mode

Press **DISPLAY**.
The display changes as follows:

When an analog radio station is received

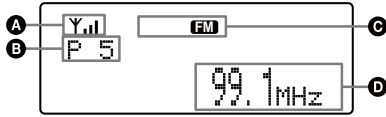

- A Field strength level indicator
- B Preset number*
- C Band
- D Frequency
- E Current time

* When you tune in a station by selecting a preset number.

When an analog FM broadcast that supports RBDS (Radio Broadcast Data System) is received

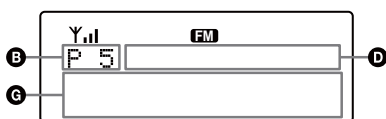
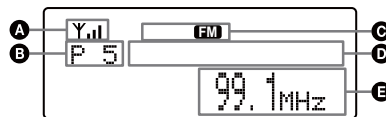

- A Field strength level indicator
- B Preset number*
- C Band
- D Station name
Name of station currently tuned in.
- E Frequency
- F Current time
- G Text information
Text information transmitted from station.

* When you tune in a station by selecting a preset number.

Note
The display item differs depending on the content of a broadcast or the station.

When an HD Radio station is received

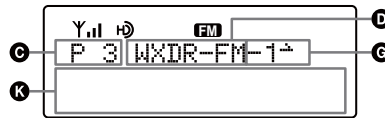
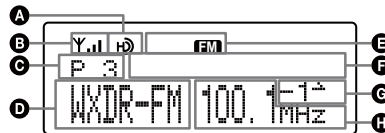

- A HD indicator
HD indicator Reception status
- | | |
|---------------|--------------------------------------|
| Stays lit | Strong HD signal, digital reception* |
| Flashes | Weak HD signal, analog reception |
| Not displayed | No HD signal, analog reception |

* The HD indicator flashes momentarily at first, and then stays lit.

- B Field strength level indicator
- C Preset number*
- D Call sign
- E Band
- F Song title/artist name
- G Channel number (FM only)
Appears when HD Radio broadcasts multiple program.
Press **TUNE +** or **-** to select a sub channel.
- H Frequency
- I Current time
- J Station name
- K Text information

* When you tune in a station by selecting a preset number

Note
The display item differs depending on the content of a broadcast or the station.

To change the display settings (BRIGHTNESS/CONTRAST)

- 1 Press **MENU** to show the menu display.
- 2 Press **SELECT** **↑** or **↓** to select "BRIGHTNESS" or "CONTRAST," then press **ENTER**.
- 3 Press **SELECT** **↑** or **↓** to select the setting or to adjust the level, then press **ENTER**.

BRIGHTNESS:
The brightness of the display is selected from "HIGH," "MIDDLE" or "LOW."

CONTRAST:
The contrast of the display can be adjusted by 11 levels.

Note
If you do not set the menu within 10 seconds, the setting mode is off.

Tip
You can adjust "BRIGHTNESS" directly by pressing **BRIGHT** on the remote commander.

Setting the sleep timer

You can enjoy falling asleep to the radio using the built-in sleep timer that turns off the radio automatically after a preset duration.

- 1 Press **SLEEP** on the remote commander. "SLEEP" and the digits for the sleep timer duration appear.



If you press **SLEEP** while the unit is turned off, the unit is turned on.

- 2 Press **SLEEP** repeatedly to select the desired sleep timer setting.

Each press changes the setting time as follows:

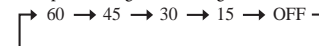

After about 4 seconds, "SLEEP" lights in the display when the duration time is set.

The unit automatically turns off when the duration time is passed.

To change the sleep timer setting

You can press **SLEEP** repeatedly to select the desired sleep timer setting even after the sleep timer has been activated.

To deactivate the sleep timer

Press **I/⏻** to turn off the unit before the setting time has elapsed, or press **SLEEP** repeatedly to set the sleep timer to "SLEEP OFF" in step 2.

Note

These operations are available only when using the remote commander.

Resetting the unit

The RESET button is located on the rear of the unit. Press this button with a pointed object if the radio fails to function properly. The clock settings and stations you have preset, etc., will revert to the factory preset.

Using the remote commander

Buttons shared on both the remote commander and the unit control the same functions.

HD SCAN button

The selected band is scanned, and receivable HD Radio stations are received for 3 seconds in order of frequency.

SCAN button

The selected band is scanned, and receivable radio stations are received for 3 seconds in order of frequency.

BRIGHT button

To adjust the brightness of the display.

Connecting the system

This section describes how to hook up the unit to the audio system. Be sure to turn off the power of each component before making the connections.

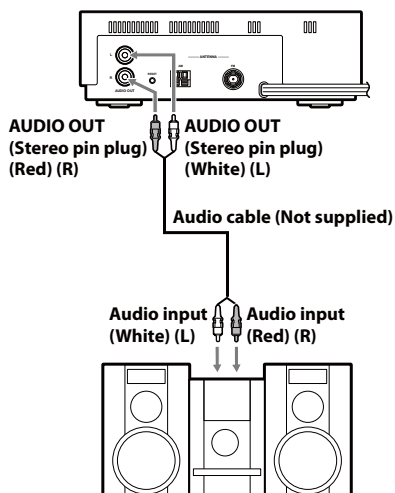

Notes

- Install this system so that the power cord can be unplugged from the wall socket immediately in the event of trouble.
- If noise occurs, separate the unit from other components.
- Noise may occur during AM reception if the unit is connected to a digital amplifier or a component equipped with a digital amplifier.

Connecting the antenna

To connect the AM loop antenna

The shape and the length of the antenna is designed to receive AM signals. Do not dismantle or roll up the antenna.

- 1 Remove only the loop part from the plastic stand.
- 2 Set up the AM loop antenna.



- 3 Connect the cords to the AM antenna terminals.
Cord (A) or cord (B) can be connected to either terminal.

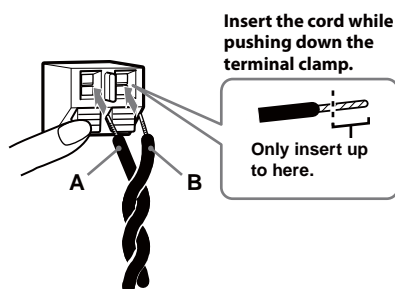

- 4 Make sure the AM loop antenna is connected firmly by pulling softly.

Adjusting the AM loop antenna

Find a place and an orientation that provide good reception.

- Do not place the AM loop antenna near the unit or other AV equipment, as noise may result.

Tip

Adjust the direction of the AM loop antenna for best AM broadcast sound.

To connect the FM antenna

This unit comes supplied with an FM dipole antenna. Connect an antenna that provides good reception to the FM antenna terminal.

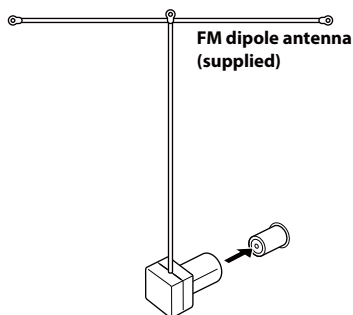

Adjusting the FM dipole antenna

Be sure to fully extend the FM dipole antenna. Attach the antenna in the shape of a T to a high position on a wall away from this unit.

Tip

If you have poor FM reception, use a 75 Ω coaxial cable (not supplied) to connect the unit to an outdoor FM antenna as shown below.

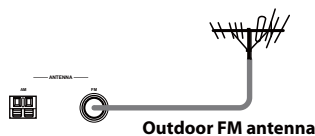

SECTION 2 DISASSEMBLY

Note: This set can be disassemble according to the following sequence.

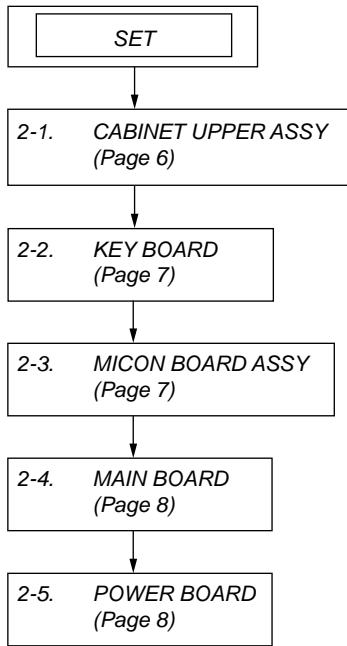

Note: Follow the disassembly procedure in the numerical order given.

2-1. CABINET UPPER ASSY

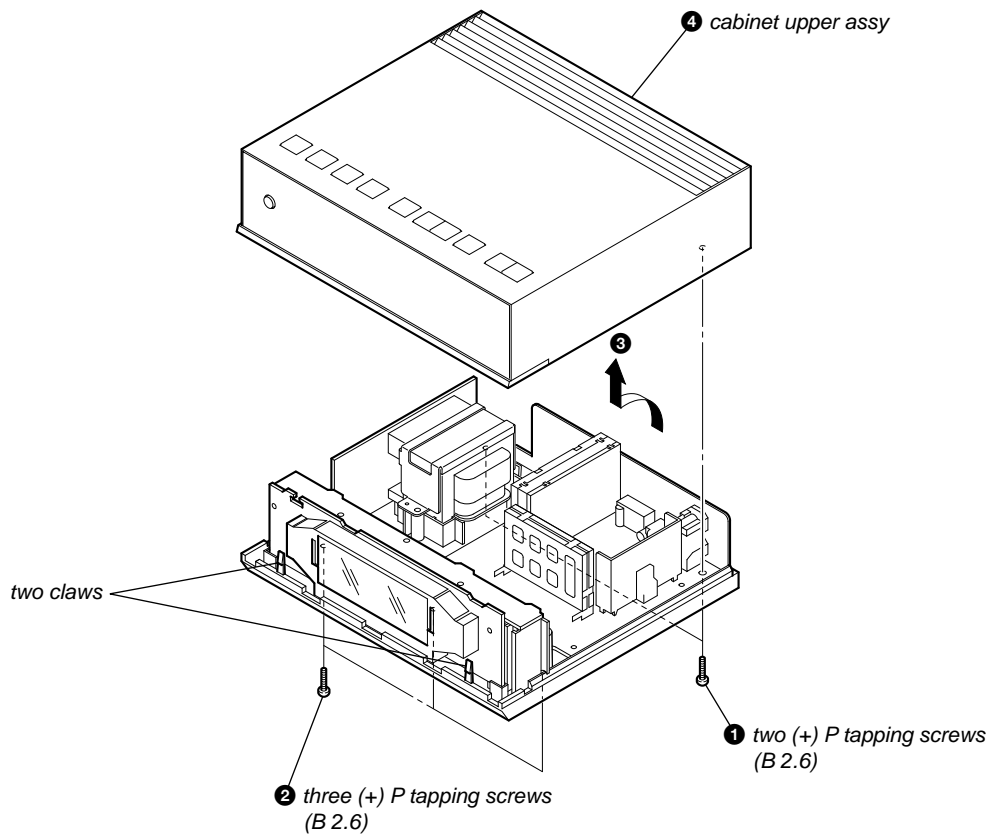

2-2. KEY BOARD

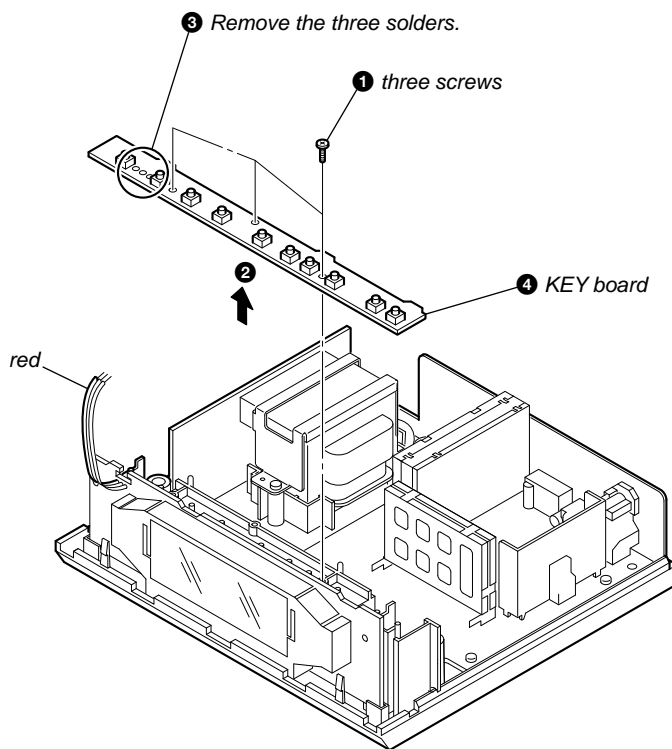

2-3. MICON BOARD ASSY

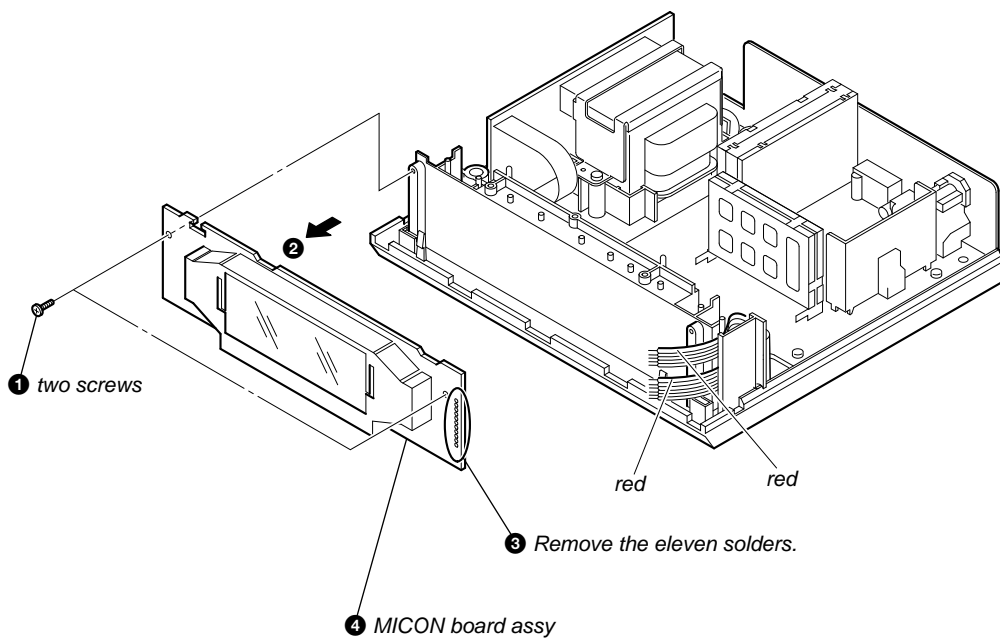

2-4. MAIN BOARD

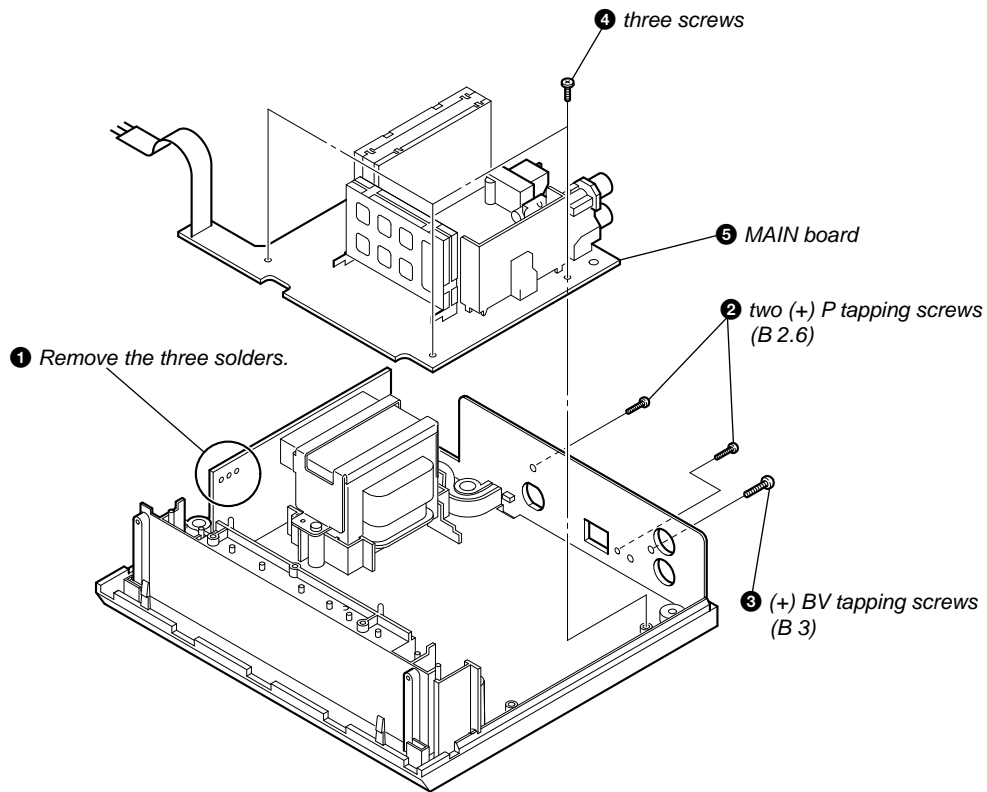

2-5. POWER BOARD

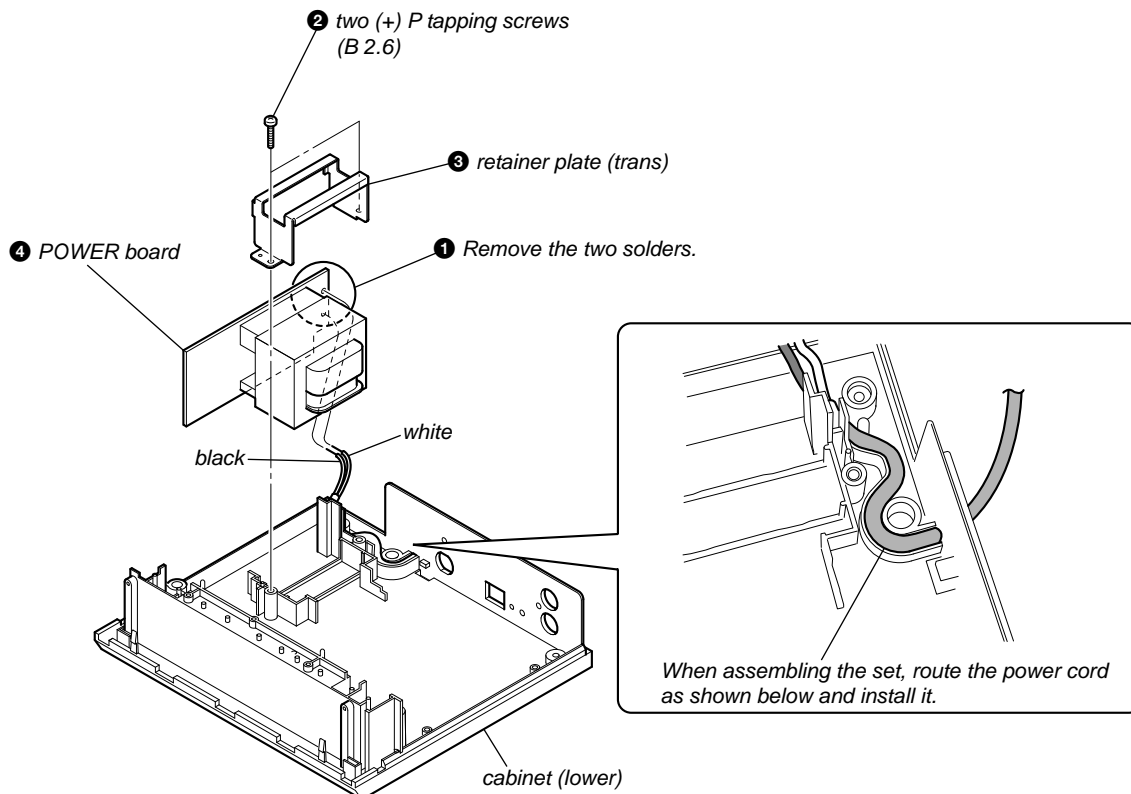

MEMO

SECTION 3 DIAGRAMS

**THIS NOTE IS COMMON FOR PRINTED WIRING BOARDS AND SCHEMATIC DIAGRAMS.
(In addition to this, the necessary note is printed in each block.)**

For Printed Wiring Boards.

Note:

- : Parts extracted from the component side.
- : Pattern from the side which enables seeing.

For Schematic Diagrams.

Note:

- All capacitors are in μF unless otherwise noted. (p: pF) 50 WV or less are not indicated except for electrolytics and tantalums.
- All resistors are in Ω and $1/4$ W or less unless otherwise specified.
- % : indicates tolerance.
- Δ : internal component.
- : panel designation.

Note: The components identified by mark Δ or dotted line with mark Δ are critical for safety.
Replace only with part number specified.

- : B+ Line.
- Voltages and waveforms are dc with respect to ground under no-signal (detuned) conditions.
no mark: FM1
- Voltages are taken with VOM (Input impedance $10\text{ M}\Omega$).
Voltage variations may be noted due to normal production tolerances.
- Waveforms are taken with an oscilloscope.
Voltage variations may be noted due to normal production tolerances.
- Circled numbers refer to waveforms.
- Signal path.
 : FM
 : AM

**• Waveforms
– MICON Board –**

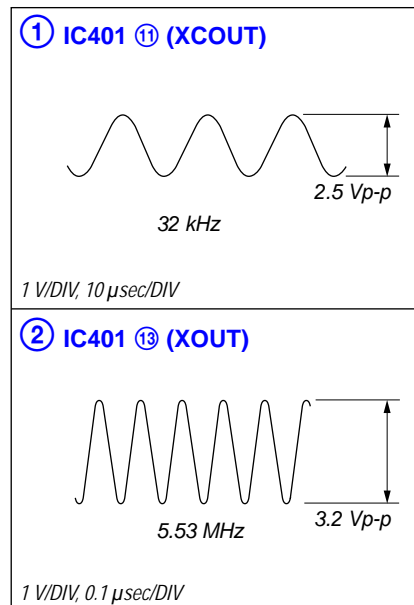

3-1. BLOCK DIAGRAM

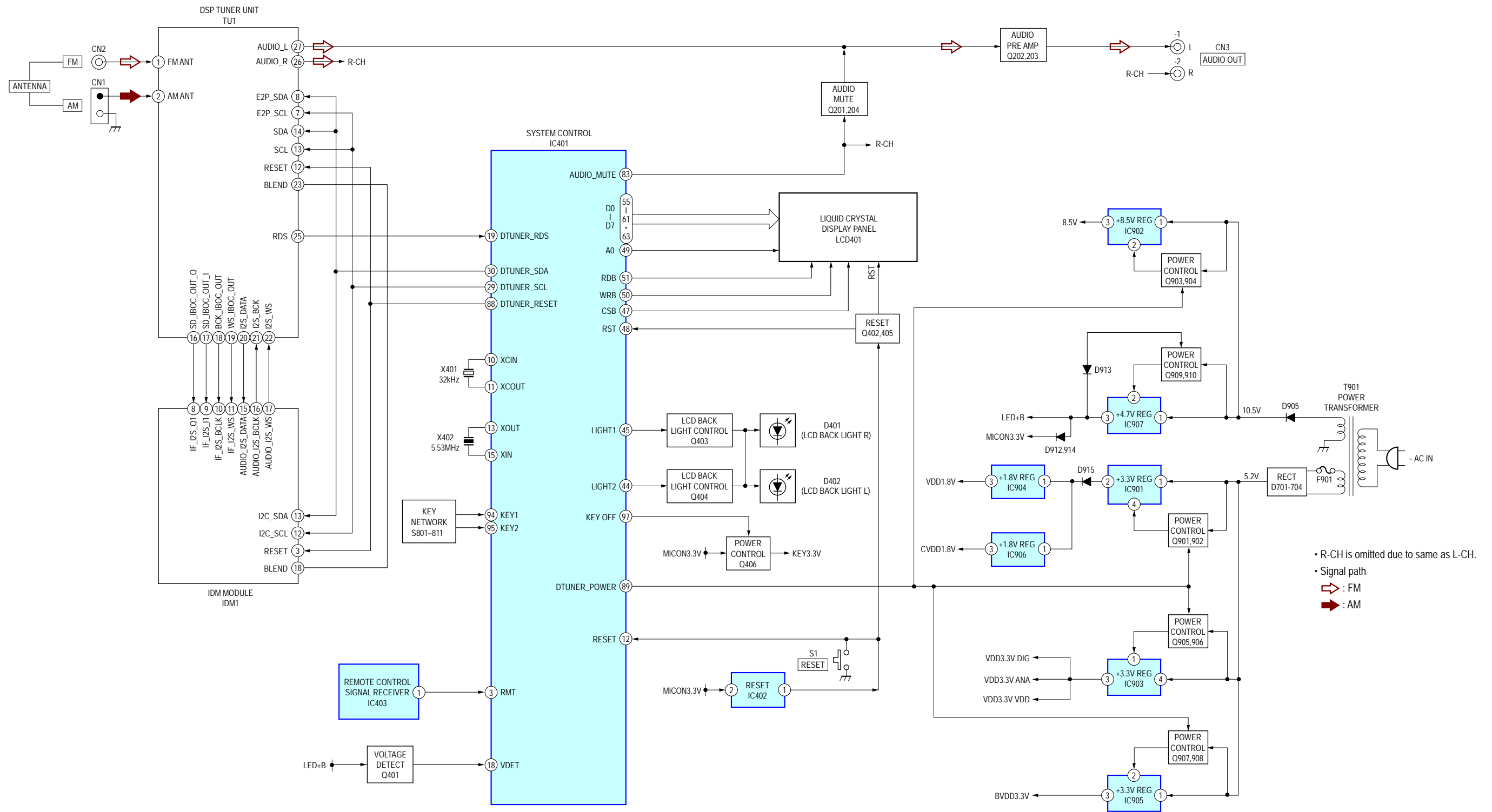

3-2. PRINTED WIRING BOARD – MAIN Section – • **LF** : Uses unleaded solder.

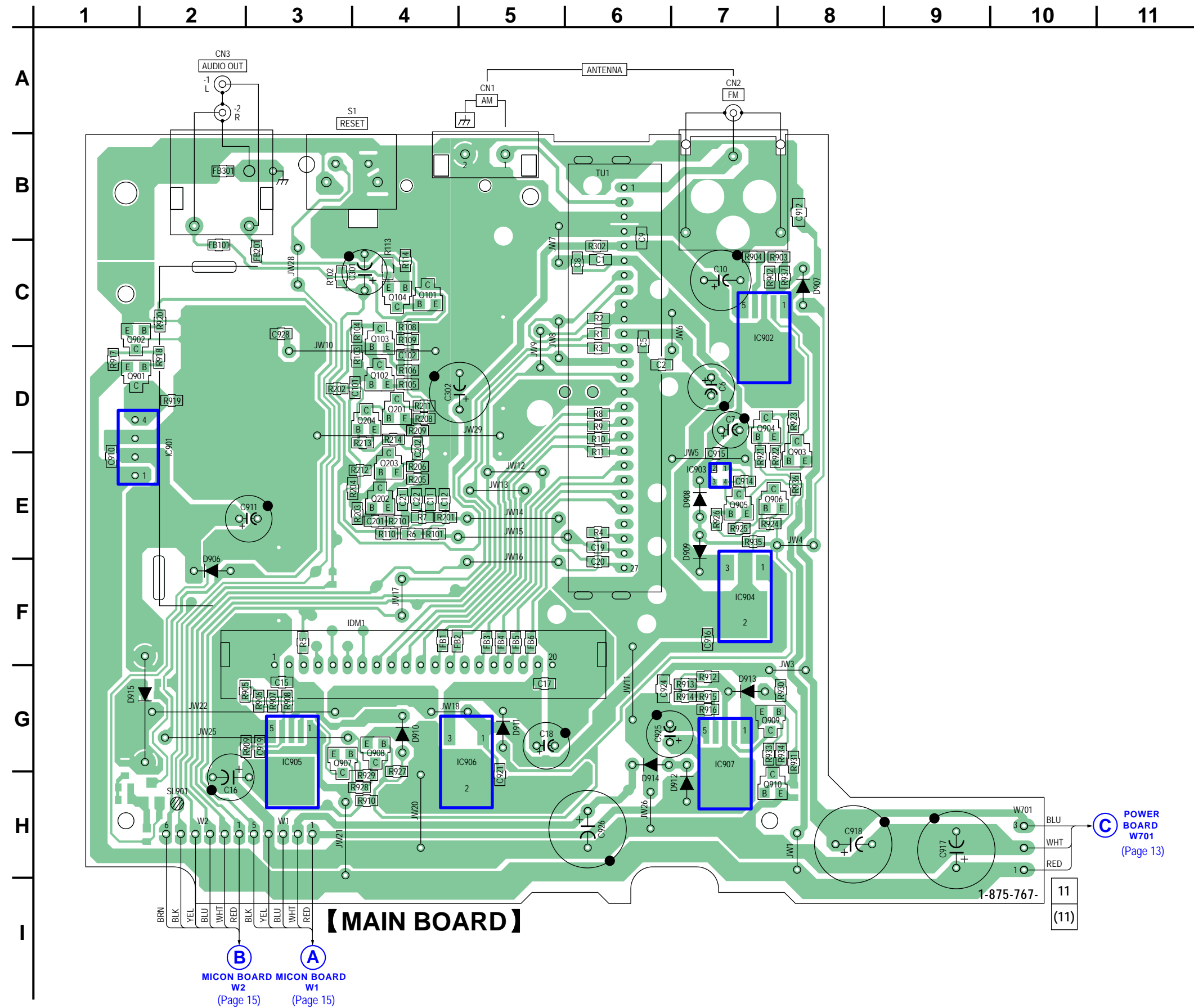

• Semiconductor Location

Ref. No.	Location	Ref. No.	Location
D906	F-2	Q101	C-4
D907	C-8	Q102	D-4
D908	E-7	Q103	C-4
D909	E-7	Q104	C-4
D910	G-4	Q201	D-4
D911	G-5	Q202	E-4
D912	H-7	Q203	E-4
D913	G-7	Q204	D-4
D914	H-6	Q901	D-1
D915	G-2	Q902	C-1
		Q903	D-8
IC901	D-2	Q904	D-7
IC902	C-7	Q905	E-7
IC903	E-7	Q906	E-7
IC904	F-7	Q907	G-3
IC905	G-3	Q908	G-4
IC906	G-5	Q909	G-7
IC907	G-7	Q910	H-7

3-3. PRINTED WIRING BOARD – POWER Section – • **LF** : Uses unleaded solder.

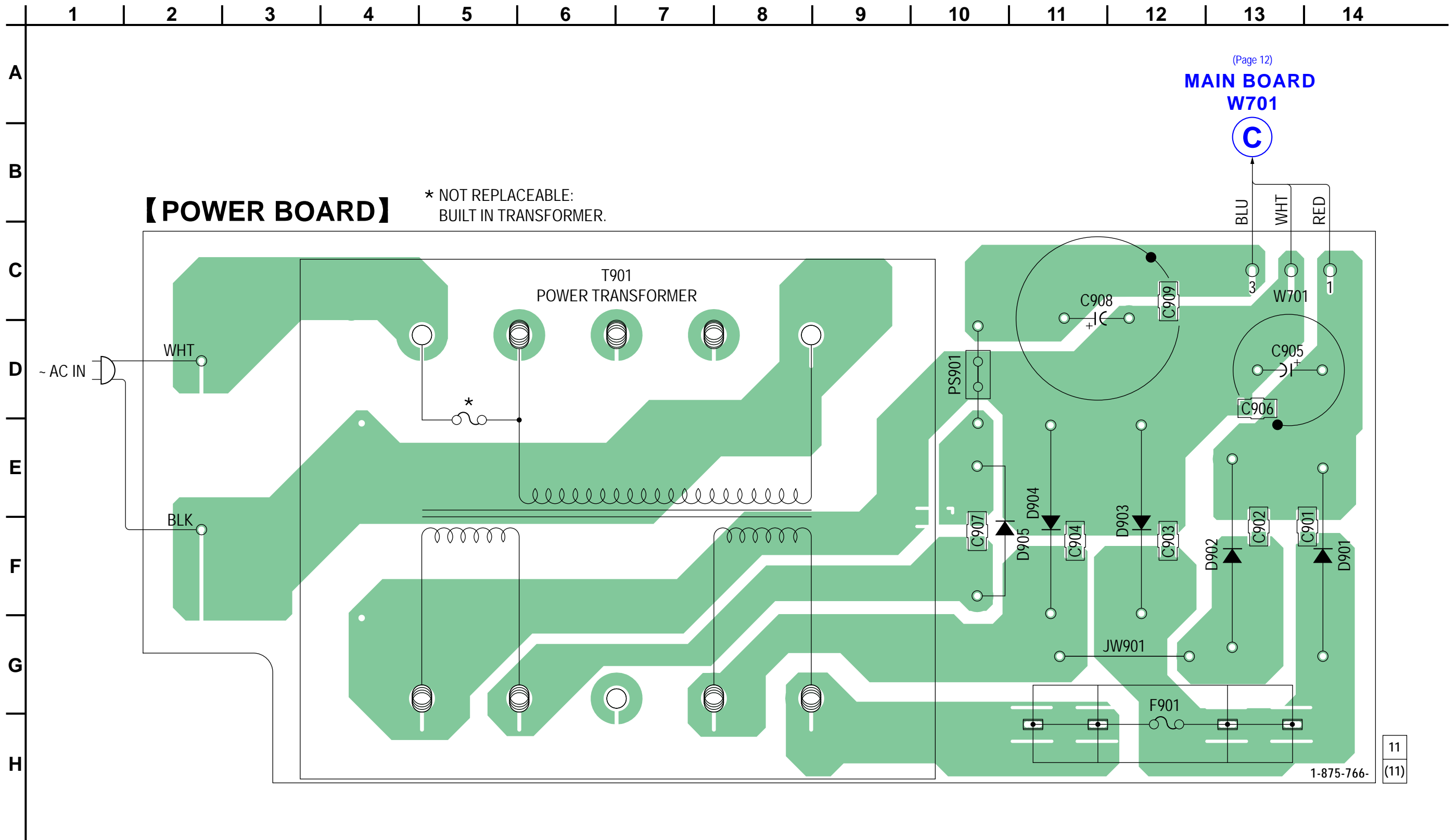

• Semiconductor Location

Ref. No.	Location
D901	F-14
D902	F-13
D903	E-12
D904	E-11
D905	F-11

11
(11)

1-875-766-

3-4. SCHEMATIC DIAGRAM – MAIN / POWER Section – • See page 17 for IC Block Diagrams.

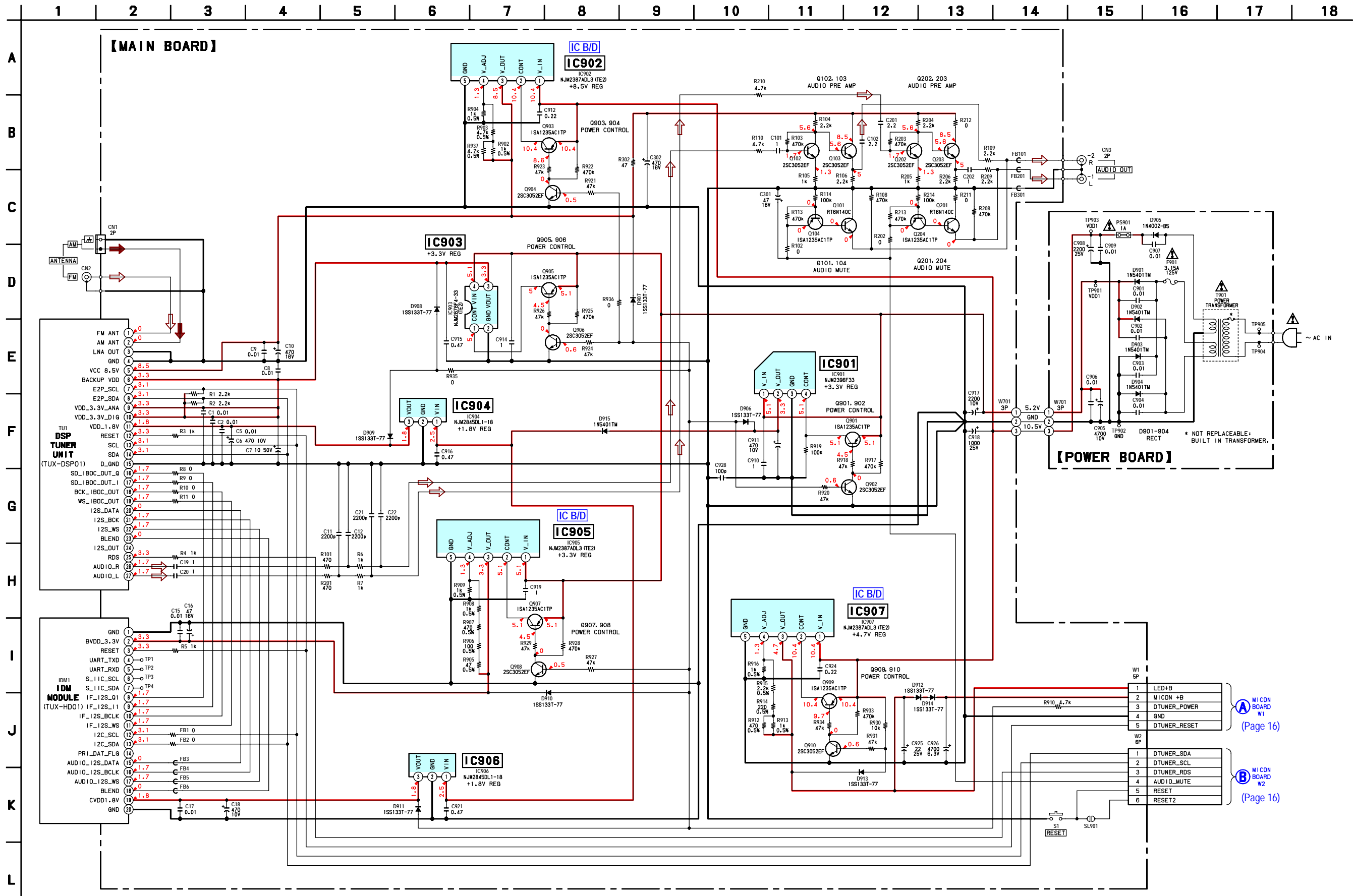

3-5. PRINTED WIRING BOARD – MICON Section – • **LF** : Uses unleaded solder.

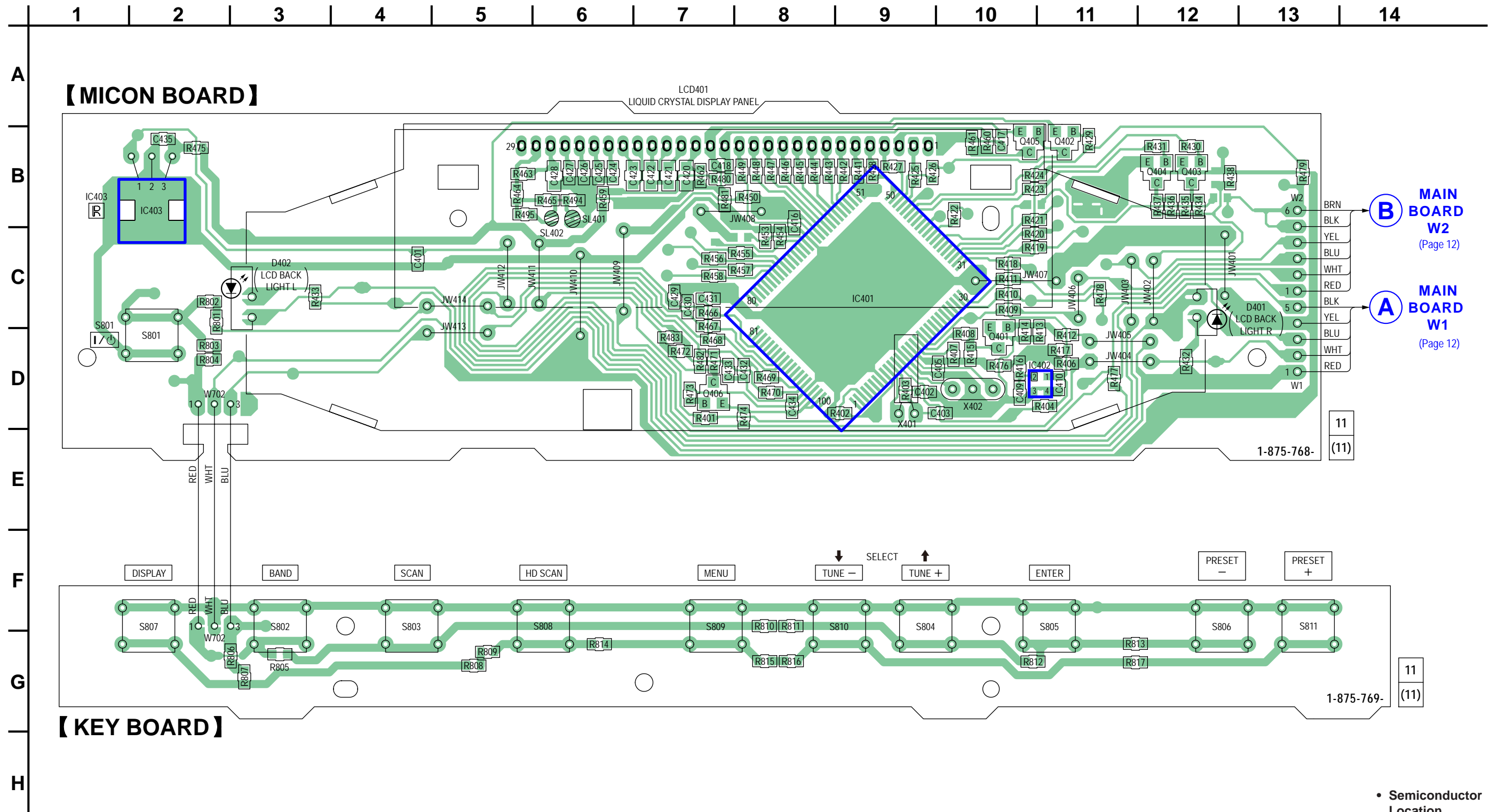

B MAIN BOARD W2 (Page 12)

A MAIN BOARD W1 (Page 12)

• Semiconductor Location

Ref. No.	Location
D401	C-13
D402	C-3
IC401	C-9
IC402	D-11
IC403	B-2
Q401	D-10
Q402	B-11
Q403	B-12
Q404	B-12
Q405	B-10
Q406	D-7

3-6. SCHEMATIC DIAGRAM – MICON Section – • See page 10 for waveforms. • See page 17 for IC Block Diagrams. • See page 18 for IC Pin Function Description.

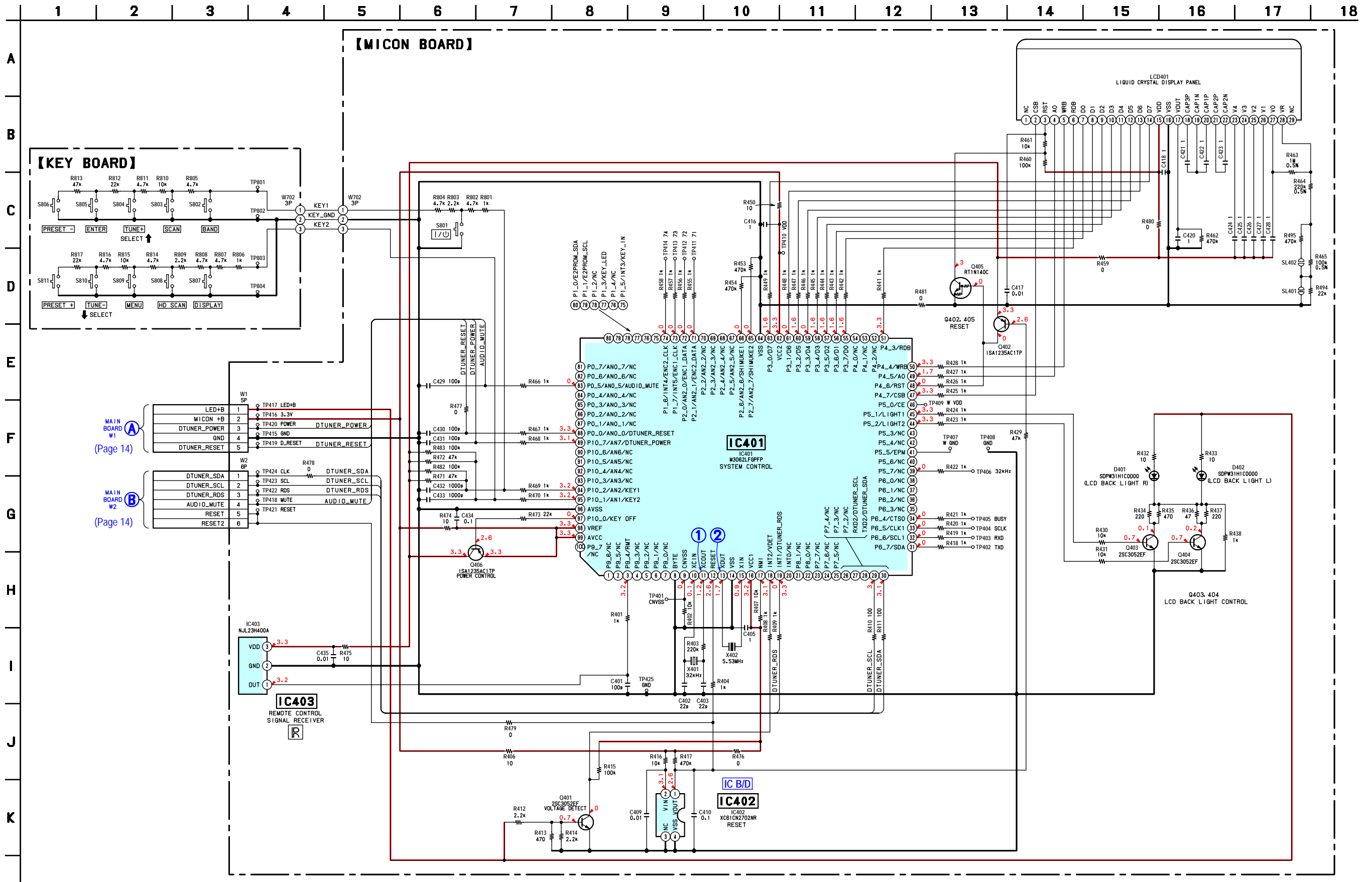

• IC Block Diagrams

IC902 NJM2387ADL3(TE2) (MAIN BOARD)
 IC905 NJM2387ADL3(TE2) (MAIN BOARD)
 IC907 NJM2387ADL3(TE2) (MAIN BOARD)

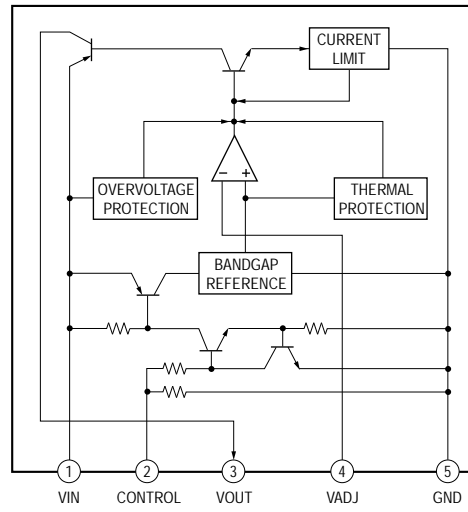

IC402 XC61CN2702NR (MICON BOARD)

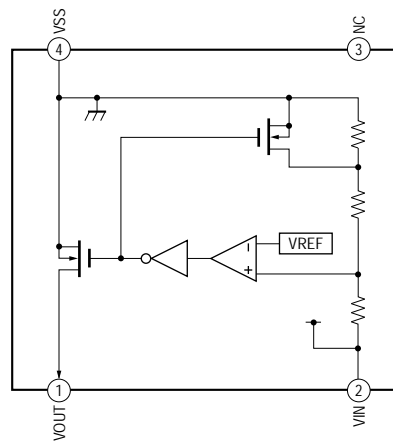

• IC Pin Function Description
MICON BOARD IC401 M3062LFGPFP (SYSTEM CONTROL)

Pin No.	Pin Name	I/O	Description
1	P9_6/NC	O	Fixed at L level (Not used)
2	P9_5/NC	O	Fixed at L level (Not used)
3	P9_4/RMT	I	Remote commander signal input
4	P9_3/NC	O	Fixed at L level (Not used)
5	P9_2/NC	O	Fixed at L level (Not used)
6	P9_1/NC	O	Fixed at L level (Not used)
7	P9_0/NC	O	Fixed at L level (Not used)
8	BYTE	I	Not used. (Connect to VSS)
9	CNVSS	I	Not used. (Fixed at L level)
10	XCIN	I	System sub clock signal input (32 kHz)
11	XCOU	O	System sub clock signal output (32 kHz)
12	RESET	I	Micon reset input (L: Micon reset)
13	XOUT	O	System main clock signal output (5.53 MHz)
14	VSS	—	Ground
15	XIN	I	System main clock signal input (5.53 MHz)
16	VCC1	—	Power supply pin (+3.3 V)
17	NMI	I	NMI interruption signal input (Fixed at H level)
18	INT2/VDDET	I	Power failure detection signal input (H: backup mode)
19	INT1/DTUNER_RDS	I	RDS data interruption signal input
20	INT0/NC	O	Fixed at L level (Not used)
21	P8_1/NC	O	Fixed at L level (Not used)
22	P8_0/NC	O	Fixed at L level (Not used)
23	P7_7/NC	O	Fixed at L level (Not used)
24	P7_6/NC	O	Fixed at L level (Not used)
25	P7_5/NC	O	Fixed at L level (Not used)
26	P7_4/NC	O	Fixed at L level (Not used)
27	P7_3/NC	O	Fixed at L level (Not used)
28	P7_2/NC	O	Fixed at L level (Not used)
29	RXD2/DTUNER_SCL	—	Communication pin for digital tuner.
30	TXD2/DTUNER_SDA	—	Communication pin for digital tuner.
31	P6_7/SDA	O	Flash write pin (Normally: output port)
32	P6_6/SCL1	O	Flash write pin (Normally: output port)
33	P6_5/CLK1	O	Flash write pin (Normally: output port)
34	P6_4/CTS0	O	Flash write pin (Normally: output port)
35	P6_3/NC	O	Fixed at L level (Not used)
36	P6_2/NC	O	Fixed at L level (Not used)
37	P6_1/NC	O	Fixed at L level (Not used)
38	P6_0/NC	O	Fixed at L level (Not used)
39	P5_7/NC	O	Flash write pin (Normally: output port)
40	P5_6/NC	O	Fixed at L level (Not used)
41	P5_5/EPM	O	Flash write pin (Normally: output port)
42	P5_4/NC	O	Fixed at L level (Not used)
43	P5_3/NC	O	Fixed at L level (Not used)
44	P5_2/LIGHT2	O	LCD back light control signal output
45	P5_1/LIGHT1	O	LCD back light control signal output
46	P5_0/CE	O	Flash write pin (Normally: output port)
47	P4_7/CSB	O	LCD driver control signal output
48	P4_6/RST	O	LCD driver reset signal output (H: driver reset)
49	P4_5/A0	O	LCD driver control signal output
50	P4_4/WRB	O	LCD driver control signal output
51	P4_3/RDB	O	LCD driver control signal output
52	P4_2/NC	O	Fixed at L level (Not used)
53	P4_1/NC	O	Fixed at L level (Not used)
54	P4_0/NC	O	Fixed at L level (Not used)

Pin No.	Pin Name	I/O	Description
55	P3_7/D0	O	LCD data output
56	P3_6/D1	O	LCD data output
57	P3_5/D2	O	LCD data output
58	P3_4/D3	O	LCD data output
59	P3_3/D4	O	LCD data output
60	P3_2/D5	O	LCD data output
61	P3_1/D6	O	LCD data output
62	VCC2	—	Power supply pin (+3.3 V)
63	P3_0/D7	O	LCD data output
64	VSS	—	Ground
65	P2_7/AN2_7/ SHIMUKE2	I	Destination select signal input (Fixed at L level)
66	P2_6/AN2_6/ SHIMUKE1	I	Destination select signal input (Fixed at L level)
67	P2_5/AN2_5/NC	O	Fixed at L level (Not used)
68	P2_4/AN2_4/NC	O	Fixed at L level (Not used)
69	P2_3/AN2_3/NC	O	Fixed at L level (Not used)
70	P2_2/AN2_2/NC	O	Fixed at L level (Not used)
71	P2_1/AN2_1/ENC2_ DATA	O	Flash write pin (Normally: output port)
72	P2_0/AN2_0/ENC1_ DATA	O	Flash write pin (Normally: output port)
73	P1_7/INT5/ENC1_ CLK	O	Flash write pin (Normally: output port)
74	P1_6/INT4/ENC2_ CLK	O	Flash write pin (Normally: output port)
75	P1_5/INT3/KEY_IN	O	Fixed at L level (Not used)
76	P1_4/NC	O	Fixed at L level (Not used)
77	P1_3/KEY_LED	O	Fixed at L level (Not used)
78	P1_2/NC	O	Fixed at L level (Not used)
79	P1_1/E2PROM_SCL	O	Fixed at L level (Not used)
80	P1_0/E2PROM_SDA	O	Fixed at L level (Not used)
81	P0_7/AN0_7/NC	O	Fixed at L level (Not used)
82	P0_6/AN0_6/NC	O	Fixed at L level (Not used)
83	P0_5/AN0_5/AU- DIO_MUTE	O	Audio mute detection signal output (H: mute ON)
84	P0_4/AN0_4/NC	O	Fixed at L level (Not used)
85	P0_3/AN0_3/NC	O	Fixed at L level (Not used)
86	P0_2/AN0_2/NC	O	Fixed at L level (Not used)
87	P0_1/AN0_1/NC	O	Fixed at L level (Not used)
88	P0_0/AN0_0/DTUN- ER_RESET	O	DSP tuner/DSP reset signal output (L: reset)
89	P10_7/AN7/DTUN- ER_POWER	O	DSP tuner power control signal output (L: radio function)
90	P10_6/AN6/NC	O	Fixed at L level (Not used)
91	P10_5/AN5/NC	O	Fixed at L level (Not used)
92	P10_4/AN4/NC	O	Fixed at L level (Not used)
93	P10_3/AN3/NC	O	Fixed at L level (Not used)
94	P10_2/AN2/KEY1	I	A/D converter analog signal input
95	P10_1/AN1/KEY2	I	A/D converter analog signal input
96	AVSS	—	Ground for A/D converter.
97	P10_0/KEY OFF	O	A/D key and remote control receiver power control signal output. (L: normally, H: backup)
98	VREF	—	Reference voltage input for A/D converter. (+3.3 V)
99	AVCC	—	Power supply pin for A/D converter. (+3.3 V)
100	P9_7/NC	O	Fixed at L level (Not used)

SECTION 4 EXPLODED VIEWS

Note:

- -XX and -X mean standardized parts, so they may have some difference from the original one.
- Items marked “*” are not stocked since they are seldom required for routine service. Some delay should be anticipated when ordering these items.

- The mechanical parts with no reference number in the exploded views are not supplied.
- Color Indication of Appearance Parts Example:
KNOB, BALANCE (WHITE) . . . (RED)

↑ Parts Color ↑ Cabinet's Color
- Accessories are given in the last of the electrical parts list.

The components identified by mark \triangle or dotted line with mark \triangle are critical for safety. Replace only with part number specified.

4-1. CABINET UPPER SECTION

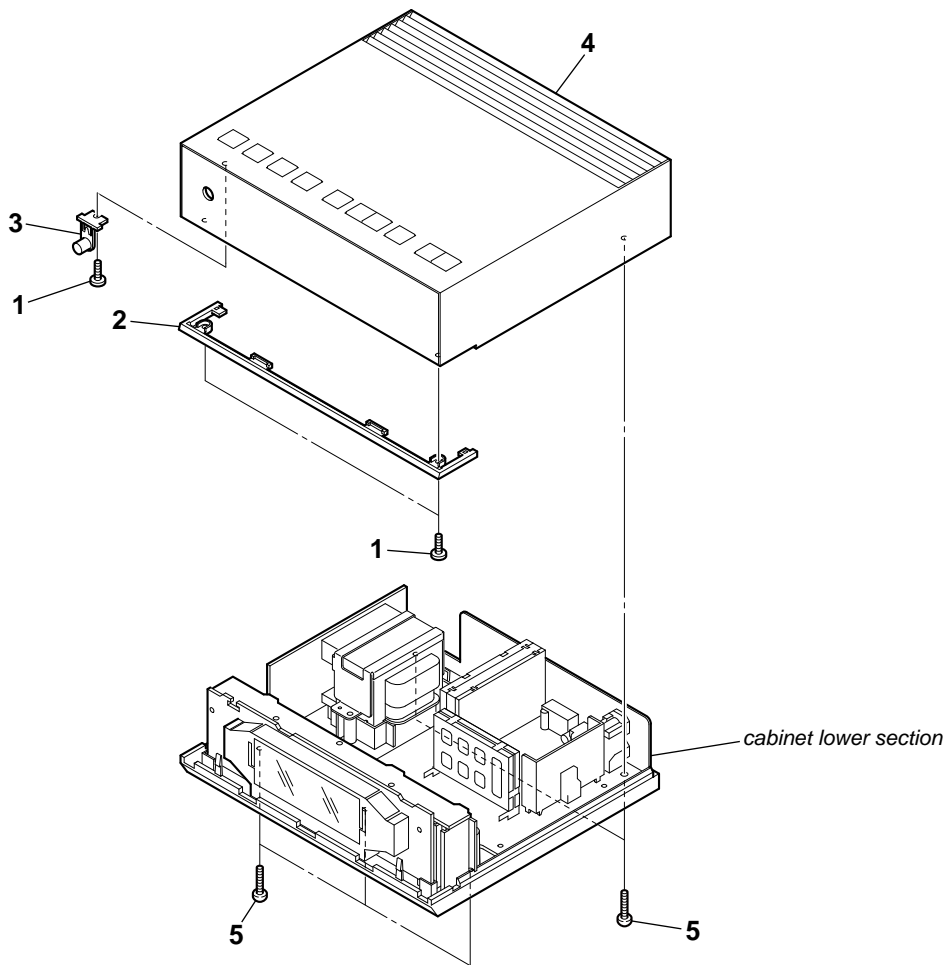

Ref. No.	Part No.	Description	Remark	Ref. No.	Part No.	Description	Remark
1	3-254-070-01	SCREW		4	X-2190-218-1	CABINET (UPPER) SUB ASSY	
2	3-284-318-01	PLATE, ORNAMENTAL		5	3-254-151-01	SCREW (B2.6), (+) P TAPPING	
3	3-284-315-01	BUTTON (PWR)					

4-2. CABINET LOWER SECTION

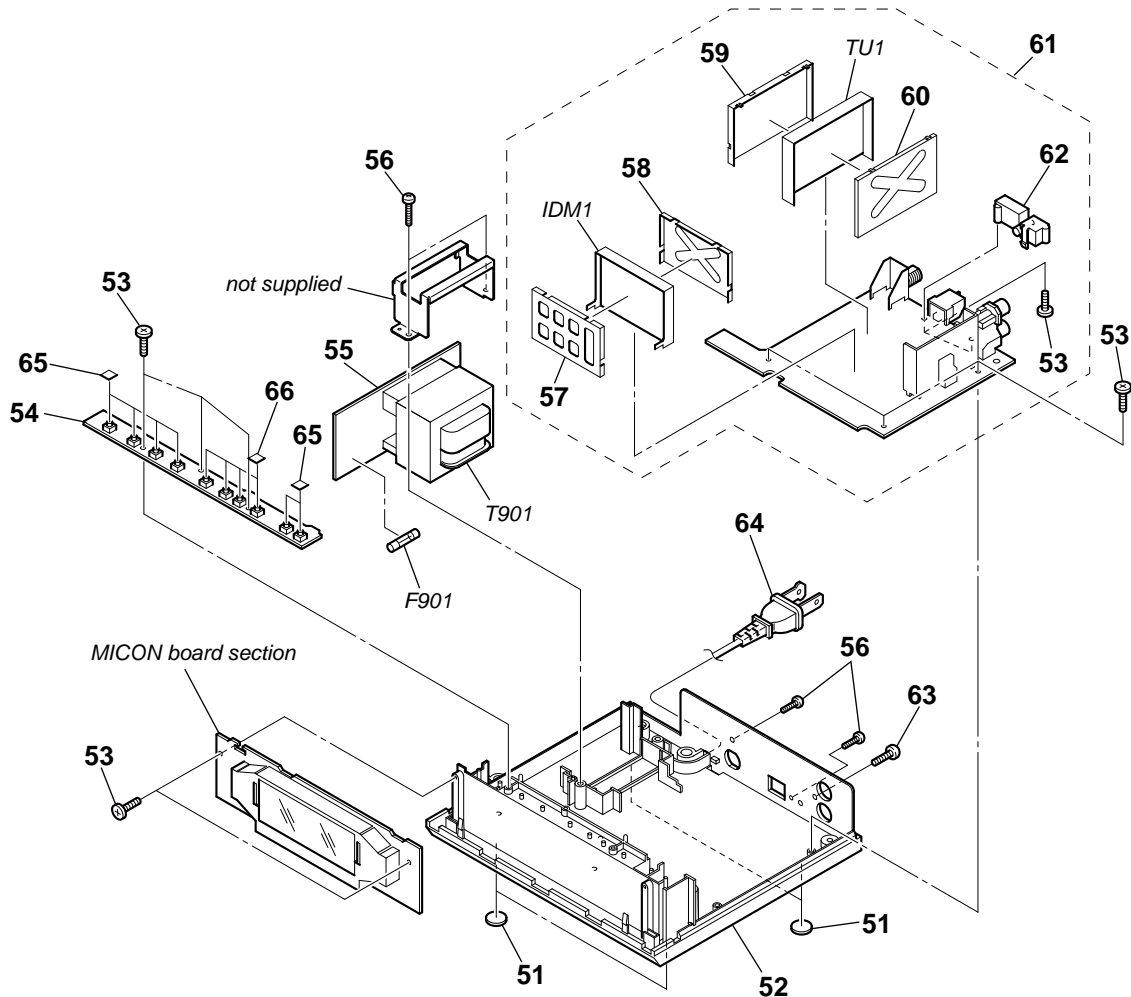

Ref. No.	Part No.	Description	Remark	Ref. No.	Part No.	Description	Remark
51	2-667-344-01	FOOT, RUBBER		61	A-1444-721-A	MAIN BOARD, COMPLETE	
52	3-284-314-01	CABINET (LOWER)		62	3-284-320-01	HOLDER (JACK)	
53	3-254-070-01	SCREW		63	3-254-143-11	SCREW (B3), (+) BV TAPPING	
54	A-1444-726-A	KEY BOARD, COMPLETE		△ 64	1-833-786-11	POWER-SUPPLY CORD	
55	A-1444-733-A	POWER BOARD, COMPLETE		65	2-631-557-01	CUSHION (SW)	
56	3-254-151-01	SCREW (B2.6), (+) P TAPPING		66	2-582-365-01	CUSHION (BUTTON)	
57	3-197-151-11	CASE (LID), SHIELD		△ F901	1-533-451-12	FUSE, GLASS TUBE (DIA. 5) (3.15A/125V)	
58	3-197-151-01	CASE (LID), SHIELD		IDM1	A-1256-714-A	IDM MODULE (TUX-HD01)	
59	3-198-659-01	COVER (DSP01, B)		△ T901	1-445-383-11	TRANSFORMER, POWER	
60	3-198-658-01	COVER (DSP01, A)		TU1	A-1256-754-A	DSP TUNER UNIT (TUX-DSP01)	

4-3. MICON BOARD SECTION

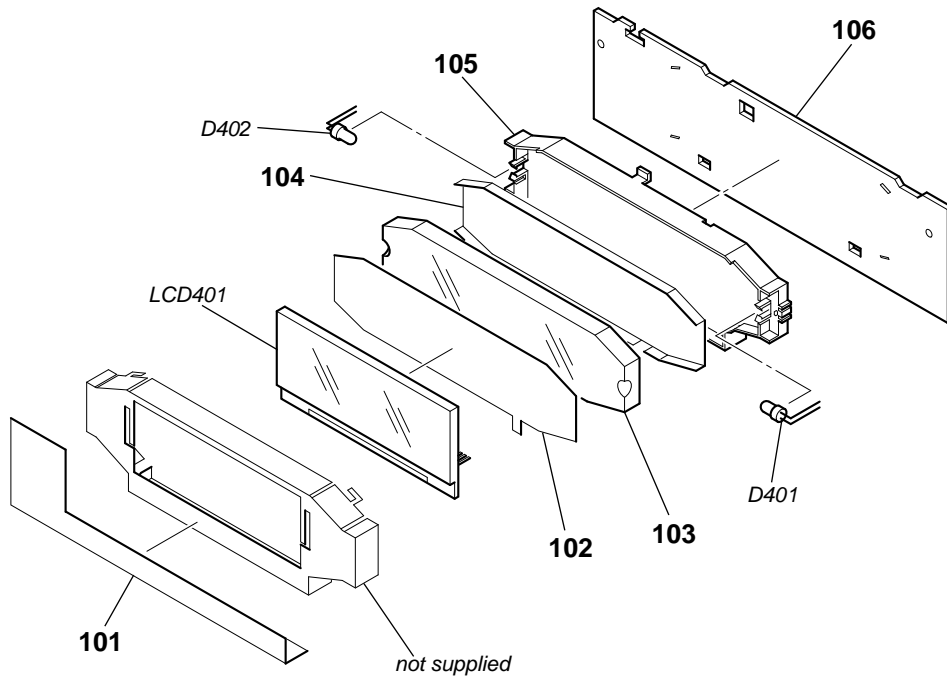

<u>Ref. No.</u>	<u>Part No.</u>	<u>Description</u>	<u>Remark</u>	<u>Ref. No.</u>	<u>Part No.</u>	<u>Description</u>	<u>Remark</u>
101	3-398-195-01	SHEET (LCD), INSULATING		106	X-2190-219-1	MICON BOARD, COMPLETE	
102	3-286-881-01	ILLUMINATOR		D401	6-502-332-01	LED SDPW31H1C0000 (LCD BACK LIGHT R)	
103	3-284-322-01	PLATE, LIGHT GUIDE		D402	6-502-332-01	LED SDPW31H1C0000 (LCD BACK LIGHT L)	
104	3-286-880-01	REFLECTOR		LCD401	1-802-620-11	DISPLAY PANEL, LIQUID CRYSTAL	
105	3-284-319-01	HOLDER (LCD)					

SECTION 5 ELECTRICAL PARTS LIST

KEY **MAIN**

Note:

- Due to standardization, replacements in the parts list may be different from the parts specified in the diagrams or the components used on the set.
- -XX and -X mean standardized parts, so they may have some difference from the original one.
- Items marked "*" are not stocked since they are seldom required for routine service. Some delay should be anticipated when ordering these items.
- CAPACITORS
uF: µF
- COILS
uH: µH

- RESISTORS
All resistors are in ohms.
METAL: Metal-film resistor.
METAL OXIDE: Metal oxide-film resistor.
F: nonflammable
- SEMICONDUCTORS
In each case, u: µ, for example:
uA. . . : µA. . . , uPA. . . , µPA. . . ,
uPB. . . : µPB. . . , uPC. . . , µPC. . . ,
uPD. . . : µPD. . .

When indicating parts by reference number, please include the board.

The components identified by mark \triangle or dotted line with mark \triangle are critical for safety.
Replace only with part number specified.

Ref. No.	Part No.	Description	Remark	Ref. No.	Part No.	Description	Remark
	A-1444-726-A	KEY BOARD, COMPLETE *****		C7	1-126-964-11	ELECT 10uF 20%	50V
		< RESISTOR >		C8	1-162-970-11	CERAMIC CHIP 0.01uF 10%	25V
R805	1-216-829-11	METAL CHIP 4.7K 5%	1/10W	C9	1-162-970-11	CERAMIC CHIP 0.01uF 10%	25V
R806	1-216-821-11	METAL CHIP 1K 5%	1/10W	C10	1-126-935-11	ELECT 470uF 20%	16V
R807	1-216-829-11	METAL CHIP 4.7K 5%	1/10W	C11	1-162-966-11	CERAMIC CHIP 0.0022uF 10%	50V
R808	1-216-829-11	METAL CHIP 4.7K 5%	1/10W	C12	1-162-966-11	CERAMIC CHIP 0.0022uF 10%	50V
R809	1-216-825-11	METAL CHIP 2.2K 5%	1/10W	C15	1-162-970-11	CERAMIC CHIP 0.01uF 10%	25V
R810	1-216-833-11	METAL CHIP 10K 5%	1/10W	C16	1-126-947-11	ELECT 47uF 20%	35V
R811	1-216-829-11	METAL CHIP 4.7K 5%	1/10W	C17	1-162-970-11	CERAMIC CHIP 0.01uF 10%	25V
R812	1-216-837-11	METAL CHIP 22K 5%	1/10W	C18	1-126-935-11	ELECT 470uF 20%	16V
R813	1-216-841-11	METAL CHIP 47K 5%	1/10W	C19	1-165-908-11	CERAMIC CHIP 1uF 10%	10V
R814	1-216-829-11	METAL CHIP 4.7K 5%	1/10W	C20	1-165-908-11	CERAMIC CHIP 1uF 10%	10V
R815	1-216-833-11	METAL CHIP 10K 5%	1/10W	C21	1-162-966-11	CERAMIC CHIP 0.0022uF 10%	50V
R816	1-216-829-11	METAL CHIP 4.7K 5%	1/10W	C22	1-162-966-11	CERAMIC CHIP 0.0022uF 10%	50V
R817	1-216-837-11	METAL CHIP 22K 5%	1/10W	C101	1-165-908-11	CERAMIC CHIP 1uF 10%	10V
		< SWITCH >		C102	1-100-742-11	CERAMIC CHIP 2.2uF 20%	10V
S802	1-798-044-11	SWITCH, TACTILE (BAND)		C201	1-165-908-11	CERAMIC CHIP 1uF 10%	10V
S803	1-798-044-11	SWITCH, TACTILE (SCAN)		C202	1-100-742-11	CERAMIC CHIP 2.2uF 20%	10V
S804	1-798-044-11	SWITCH, TACTILE (TUNE+/SELECT \uparrow)		C301	1-126-947-11	ELECT 47uF 20%	35V
S805	1-798-044-11	SWITCH, TACTILE (ENTER)		C302	1-126-935-11	ELECT 470uF 20%	16V
S806	1-798-044-11	SWITCH, TACTILE (PRESET -)		C910	1-165-908-11	CERAMIC CHIP 1uF 10%	10V
S807	1-798-044-11	SWITCH, TACTILE (DISPLAY)		C911	1-126-935-11	ELECT 470uF 20%	16V
S808	1-798-044-11	SWITCH, TACTILE (HD SCAN)		C912	1-115-340-11	CERAMIC CHIP 0.22uF 10%	25V
S809	1-798-044-11	SWITCH, TACTILE (MENU)		C914	1-165-908-11	CERAMIC CHIP 1uF 10%	10V
S810	1-798-044-11	SWITCH, TACTILE (TUNE-/SELECT \downarrow)		C915	1-125-891-11	CERAMIC CHIP 0.47uF 10%	10V
S811	1-798-044-11	SWITCH, TACTILE (PRESET +)		C916	1-125-891-11	CERAMIC CHIP 0.47uF 10%	10V
*****				C917	1-126-927-11	ELECT 2200uF 20%	10V
	A-1444-721-A	MAIN BOARD, COMPLETE *****		C918	1-126-942-61	ELECT 1000uF 20%	25V
	3-197-151-01	CASE (LID), SHIELD		C919	1-165-908-11	CERAMIC CHIP 1uF 10%	10V
	3-197-151-11	CASE (LID), SHIELD		C921	1-125-891-11	CERAMIC CHIP 0.47uF 10%	10V
	3-198-658-01	COVER (DSP01, A)		C924	1-115-340-11	CERAMIC CHIP 0.22uF 10%	25V
	3-198-659-01	COVER (DSP01, B)		C925	1-128-551-11	ELECT 22uF 20%	63V
	3-254-070-01	SCREW		C926	1-126-918-11	ELECT 4700uF 20%	6.3V
	3-254-151-01	SCREW (B2.6), (+) P TAPPING		C928	1-162-927-11	CERAMIC CHIP 100PF 5%	50V
	3-284-320-01	HOLDER (JACK)				< TERMINAL BOARD >	
		< CAPACITOR >		CN1	1-780-519-11	TERMINAL BOARD (ANTENNA 2P)	(ANTENNA AM)
C1	1-162-970-11	CERAMIC CHIP 0.01uF 10%	25V			< CONNECTOR >	
C2	1-162-970-11	CERAMIC CHIP 0.01uF 10%	25V	CN2	1-815-513-22	CONNECTOR, COAXIAL (F TYPE) (ANTENNA FM)	
C5	1-162-970-11	CERAMIC CHIP 0.01uF 10%	25V			< JACK >	
C6	1-126-935-11	ELECT 470uF 20%	16V	CN3	1-793-987-11	JACK, PIN 2P (AUDIO OUT)	

XDR-F1HD

MAIN

Ref. No.	Part No.	Description	Remark	Ref. No.	Part No.	Description	Remark
		< DIODE >					
D906	8-719-991-33	DIODE 1SS133T-77		R5	1-216-821-11	METAL CHIP 1K 5%	1/10W
D907	8-719-991-33	DIODE 1SS133T-77		R6	1-216-821-11	METAL CHIP 1K 5%	1/10W
D908	8-719-991-33	DIODE 1SS133T-77		R7	1-216-821-11	METAL CHIP 1K 5%	1/10W
D909	8-719-991-33	DIODE 1SS133T-77		R8	1-216-864-11	SHORT CHIP 0	
D910	8-719-991-33	DIODE 1SS133T-77		R9	1-216-864-11	SHORT CHIP 0	
D911	8-719-991-33	DIODE 1SS133T-77		R10	1-216-864-11	SHORT CHIP 0	
D912	8-719-991-33	DIODE 1SS133T-77		R11	1-216-864-11	SHORT CHIP 0	
D913	8-719-991-33	DIODE 1SS133T-77		R101	1-216-817-11	METAL CHIP 470 5%	1/10W
D914	8-719-991-33	DIODE 1SS133T-77		R102	1-216-864-11	SHORT CHIP 0	
D915	8-719-046-47	DIODE 1N5401TM		R103	1-216-853-11	METAL CHIP 470K 5%	1/10W
		< FERRITE BEAD >		R104	1-216-825-11	METAL CHIP 2.2K 5%	1/10W
FB1	1-216-864-11	SHORT CHIP 0		R105	1-216-821-11	METAL CHIP 1K 5%	1/10W
FB2	1-216-864-11	SHORT CHIP 0		R106	1-216-825-11	METAL CHIP 2.2K 5%	1/10W
FB3	1-414-227-11	INDUCTOR, FERRITE BEAD		R108	1-216-853-11	METAL CHIP 470K 5%	1/10W
FB4	1-414-227-11	INDUCTOR, FERRITE BEAD		R109	1-216-825-11	METAL CHIP 2.2K 5%	1/10W
FB5	1-414-227-11	INDUCTOR, FERRITE BEAD		R110	1-216-829-11	METAL CHIP 4.7K 5%	1/10W
FB6	1-414-227-11	INDUCTOR, FERRITE BEAD		R113	1-216-853-11	METAL CHIP 470K 5%	1/10W
FB101	1-414-227-11	INDUCTOR, FERRITE BEAD		R114	1-216-845-11	METAL CHIP 100K 5%	1/10W
FB201	1-414-227-11	INDUCTOR, FERRITE BEAD		R201	1-216-817-11	METAL CHIP 470 5%	1/10W
FB301	1-414-227-11	INDUCTOR, FERRITE BEAD		R202	1-216-864-11	SHORT CHIP 0	
		< IC >		R203	1-216-853-11	METAL CHIP 470K 5%	1/10W
IC901	6-712-237-01	IC NJM2396F33		R204	1-216-825-11	METAL CHIP 2.2K 5%	1/10W
IC902	6-709-213-01	IC NJM2387ADL3(TE2)		R205	1-216-821-11	METAL CHIP 1K 5%	1/10W
IC903	6-710-536-01	IC NJM2878F4-33(TE2)		R206	1-216-825-11	METAL CHIP 2.2K 5%	1/10W
IC904	6-712-238-01	IC NJM2845DL1-18		R208	1-216-853-11	METAL CHIP 470K 5%	1/10W
IC905	6-709-213-01	IC NJM2387ADL3(TE2)		R209	1-216-825-11	METAL CHIP 2.2K 5%	1/10W
IC906	6-712-238-01	IC NJM2845DL1-18		R210	1-216-829-11	METAL CHIP 4.7K 5%	1/10W
IC907	6-709-213-01	IC NJM2387ADL3(TE2)		R211	1-216-864-11	SHORT CHIP 0	
		< IDM MODULE >		R212	1-216-864-11	SHORT CHIP 0	
IDM1	A-1256-714-A	IDM MODULE (TUX-HD01)		R213	1-216-853-11	METAL CHIP 470K 5%	1/10W
		< TRANSISTOR >		R214	1-216-845-11	METAL CHIP 100K 5%	1/10W
Q101	6-551-392-01	TRANSISTOR RT6N140C-TP-1		R302	1-216-805-11	METAL CHIP 47 5%	1/10W
Q102	8-729-620-07	TRANSISTOR 2SC3052EF-T1-LEF		R902	1-218-847-11	METAL CHIP 1K 0.5%	1/10W
Q103	8-729-620-07	TRANSISTOR 2SC3052EF-T1-LEF		R903	1-218-863-11	METAL CHIP 4.7K 0.5%	1/10W
Q104	6-551-696-01	TRANSISTOR ISA1235AC1TP-1EF		R904	1-218-847-11	METAL CHIP 1K 0.5%	1/10W
Q201	6-551-392-01	TRANSISTOR RT6N140C-TP-1		R905	1-211-985-11	METAL CHIP 47 0.5%	1/10W
Q202	8-729-620-07	TRANSISTOR 2SC3052EF-T1-LEF		R906	1-218-823-11	METAL CHIP 100 0.5%	1/10W
Q203	8-729-620-07	TRANSISTOR 2SC3052EF-T1-LEF		R907	1-218-839-11	METAL CHIP 470 0.5%	1/10W
Q204	6-551-696-01	TRANSISTOR ISA1235AC1TP-1EF		R908	1-218-847-11	METAL CHIP 1K 0.5%	1/10W
Q901	6-551-696-01	TRANSISTOR ISA1235AC1TP-1EF		R909	1-218-847-11	METAL CHIP 1K 0.5%	1/10W
Q902	8-729-620-07	TRANSISTOR 2SC3052EF-T1-LEF		R910	1-216-829-11	METAL CHIP 4.7K 5%	1/10W
Q903	6-551-696-01	TRANSISTOR ISA1235AC1TP-1EF		R912	1-218-839-11	METAL CHIP 470 0.5%	1/10W
Q904	8-729-620-07	TRANSISTOR 2SC3052EF-T1-LEF		R913	1-218-847-11	METAL CHIP 1K 0.5%	1/10W
Q905	6-551-696-01	TRANSISTOR ISA1235AC1TP-1EF		R914	1-218-831-11	METAL CHIP 220 0.5%	1/10W
Q906	8-729-620-07	TRANSISTOR 2SC3052EF-T1-LEF		R915	1-218-855-11	METAL CHIP 2.2K 0.5%	1/10W
Q907	6-551-696-01	TRANSISTOR ISA1235AC1TP-1EF		R916	1-218-847-11	METAL CHIP 1K 0.5%	1/10W
Q908	8-729-620-07	TRANSISTOR 2SC3052EF-T1-LEF		R917	1-216-853-11	METAL CHIP 470K 5%	1/10W
Q909	6-551-696-01	TRANSISTOR ISA1235AC1TP-1EF		R918	1-216-841-11	METAL CHIP 47K 5%	1/10W
Q910	8-729-620-07	TRANSISTOR 2SC3052EF-T1-LEF		R919	1-216-845-11	METAL CHIP 100K 5%	1/10W
		< RESISTOR >		R920	1-216-841-11	METAL CHIP 47K 5%	1/10W
R1	1-216-825-11	METAL CHIP 2.2K 5%	1/10W	R921	1-216-841-11	METAL CHIP 47K 5%	1/10W
R2	1-216-825-11	METAL CHIP 2.2K 5%	1/10W	R922	1-216-853-11	METAL CHIP 470K 5%	1/10W
R3	1-216-821-11	METAL CHIP 1K 5%	1/10W	R923	1-216-841-11	METAL CHIP 47K 5%	1/10W
R4	1-216-821-11	METAL CHIP 1K 5%	1/10W	R924	1-216-841-11	METAL CHIP 47K 5%	1/10W
				R925	1-216-853-11	METAL CHIP 470K 5%	1/10W
				R926	1-216-841-11	METAL CHIP 47K 5%	1/10W
				R927	1-216-841-11	METAL CHIP 47K 5%	1/10W
				R928	1-216-853-11	METAL CHIP 470K 5%	1/10W
				R929	1-216-841-11	METAL CHIP 47K 5%	1/10W
				R930	1-216-833-11	METAL CHIP 10K 5%	1/10W

Ref. No.	Part No.	Description	Remark	Ref. No.	Part No.	Description	Remark
R931	1-216-841-11	METAL CHIP 47K	5% 1/10W	R403	1-216-849-11	METAL CHIP 220K	5% 1/10W
R933	1-216-853-11	METAL CHIP 470K	5% 1/10W	R404	1-216-821-11	METAL CHIP 1K	5% 1/10W
R934	1-216-841-11	METAL CHIP 47K	5% 1/10W	R406	1-216-797-11	METAL CHIP 10	5% 1/10W
R935	1-216-864-11	SHORT CHIP 0		R407	1-216-833-11	METAL CHIP 10K	5% 1/10W
R936	1-216-864-11	SHORT CHIP 0		R408	1-216-821-11	METAL CHIP 1K	5% 1/10W
R937	1-218-863-11	METAL CHIP 4.7K	0.5% 1/10W	R409	1-216-821-11	METAL CHIP 1K	5% 1/10W
		< SWITCH >		R410	1-216-809-11	METAL CHIP 100	5% 1/10W
S1	1-554-088-00	SWITCH, KEYBOARD (RESET)		R411	1-216-809-11	METAL CHIP 100	5% 1/10W
		< TUNER UNIT >		R412	1-216-825-11	METAL CHIP 2.2K	5% 1/10W
TU1	A-1256-754-A	DSP TUNER UNIT (TUX-DSP01)		R413	1-216-817-11	METAL CHIP 470	5% 1/10W

	X-2190-219-1	MICON BOARD, COMPLETE		R414	1-216-825-11	METAL CHIP 2.2K	5% 1/10W
		*****		R415	1-216-845-11	METAL CHIP 100K	5% 1/10W
		< CAPACITOR >		R416	1-216-833-11	METAL CHIP 10K	5% 1/10W
C401	1-162-927-11	CERAMIC CHIP 100PF	5% 50V	R417	1-216-853-11	METAL CHIP 470K	5% 1/10W
C402	1-162-919-11	CERAMIC CHIP 22PF	5% 50V	R418	1-216-821-11	METAL CHIP 1K	5% 1/10W
C403	1-162-919-11	CERAMIC CHIP 22PF	5% 50V	R419	1-216-821-11	METAL CHIP 1K	5% 1/10W
C405	1-115-156-11	CERAMIC CHIP 1uF	10V	R420	1-216-821-11	METAL CHIP 1K	5% 1/10W
C409	1-162-970-11	CERAMIC CHIP 0.01uF	10% 25V	R421	1-216-821-11	METAL CHIP 1K	5% 1/10W
C410	1-107-826-11	CERAMIC CHIP 0.1uF	10% 16V	R422	1-216-821-11	METAL CHIP 1K	5% 1/10W
C416	1-115-156-11	CERAMIC CHIP 1uF	10V	R423	1-216-821-11	METAL CHIP 1K	5% 1/10W
C417	1-162-970-11	CERAMIC CHIP 0.01uF	10% 25V	R424	1-216-821-11	METAL CHIP 1K	5% 1/10W
C418	1-115-156-11	CERAMIC CHIP 1uF	10V	R425	1-216-821-11	METAL CHIP 1K	5% 1/10W
C420	1-164-346-11	CERAMIC CHIP 1uF	16V	R426	1-216-821-11	METAL CHIP 1K	5% 1/10W
C421	1-164-346-11	CERAMIC CHIP 1uF	16V	R427	1-216-821-11	METAL CHIP 1K	5% 1/10W
C422	1-164-346-11	CERAMIC CHIP 1uF	16V	R428	1-216-821-11	METAL CHIP 1K	5% 1/10W
C423	1-164-346-11	CERAMIC CHIP 1uF	16V	R429	1-216-841-11	METAL CHIP 47K	5% 1/10W
C424	1-115-156-11	CERAMIC CHIP 1uF	10V	R430	1-216-833-11	METAL CHIP 10K	5% 1/10W
C425	1-115-156-11	CERAMIC CHIP 1uF	10V	R431	1-216-833-11	METAL CHIP 10K	5% 1/10W
C426	1-115-156-11	CERAMIC CHIP 1uF	10V	R432	1-216-797-11	METAL CHIP 10	5% 1/10W
C427	1-115-156-11	CERAMIC CHIP 1uF	10V	R433	1-216-797-11	METAL CHIP 10	5% 1/10W
C428	1-164-346-11	CERAMIC CHIP 1uF	16V	R434	1-216-813-11	METAL CHIP 220	5% 1/10W
C429	1-162-927-11	CERAMIC CHIP 100PF	5% 50V	R435	1-216-817-11	METAL CHIP 470	5% 1/10W
C430	1-162-927-11	CERAMIC CHIP 100PF	5% 50V	R436	1-216-805-11	METAL CHIP 47	5% 1/10W
C431	1-162-927-11	CERAMIC CHIP 100PF	5% 50V	R437	1-216-813-11	METAL CHIP 220	5% 1/10W
C432	1-162-964-11	CERAMIC CHIP 0.001uF	10% 50V	R438	1-216-821-11	METAL CHIP 1K	5% 1/10W
C433	1-162-964-11	CERAMIC CHIP 0.001uF	10% 50V	R441	1-216-821-11	METAL CHIP 1K	5% 1/10W
C434	1-107-826-11	CERAMIC CHIP 0.1uF	10% 16V	R442	1-216-821-11	METAL CHIP 1K	5% 1/10W
C435	1-162-970-11	CERAMIC CHIP 0.01uF	10% 25V	R443	1-216-821-11	METAL CHIP 1K	5% 1/10W
		< IC >		R444	1-216-821-11	METAL CHIP 1K	5% 1/10W
IC401	(Not supplied)	IC M3062LFGPPF		R445	1-216-821-11	METAL CHIP 1K	5% 1/10W
IC402	6-702-148-01	IC XC61CN2702NR		R446	1-216-821-11	METAL CHIP 1K	5% 1/10W
IC403	6-600-349-21	IC NJL23H400A (IR)		R447	1-216-821-11	METAL CHIP 1K	5% 1/10W
		< TRANSISTOR >		R448	1-216-821-11	METAL CHIP 1K	5% 1/10W
Q401	8-729-620-07	TRANSISTOR 2SC3052EF-T1-LEF		R449	1-216-821-11	METAL CHIP 1K	5% 1/10W
Q402	6-551-696-01	TRANSISTOR ISA1235AC1TP-1EF		R450	1-216-797-11	METAL CHIP 10	5% 1/10W
Q403	8-729-620-07	TRANSISTOR 2SC3052EF-T1-LEF		R453	1-216-853-11	METAL CHIP 470K	5% 1/10W
Q404	8-729-620-07	TRANSISTOR 2SC3052EF-T1-LEF		R454	1-216-853-11	METAL CHIP 470K	5% 1/10W
Q405	8-729-027-44	TRANSISTOR DTC114TKA-T146		R455	1-216-821-11	METAL CHIP 1K	5% 1/10W
Q406	6-551-696-01	TRANSISTOR ISA1235AC1TP-1EF		R456	1-216-821-11	METAL CHIP 1K	5% 1/10W
		< RESISTOR >		R457	1-216-821-11	METAL CHIP 1K	5% 1/10W
R401	1-216-821-11	METAL CHIP 1K	5% 1/10W	R458	1-216-821-11	METAL CHIP 1K	5% 1/10W
R402	1-216-833-11	METAL CHIP 10K	5% 1/10W	R459	1-216-864-11	SHORT CHIP 0	
				R460	1-216-845-11	METAL CHIP 100K	5% 1/10W
				R461	1-216-833-11	METAL CHIP 10K	5% 1/10W
				R462	1-216-853-11	METAL CHIP 470K	5% 1/10W
				R463	1-216-857-11	METAL CHIP 1M	5% 1/10W
				R464	1-218-903-11	METAL CHIP 220K	0.5% 1/10W
				R465	1-218-895-11	METAL CHIP 100K	0.5% 1/10W
				R466	1-216-821-11	METAL CHIP 1K	5% 1/10W
				R467	1-216-821-11	METAL CHIP 1K	5% 1/10W

XDR-F1HD

MICON **POWER**

Ref. No.	Part No.	Description	Remark
R468	1-216-821-11	METAL CHIP 1K 5%	1/10W
R469	1-216-821-11	METAL CHIP 1K 5%	1/10W
R470	1-216-821-11	METAL CHIP 1K 5%	1/10W
R471	1-216-841-11	METAL CHIP 47K 5%	1/10W
R472	1-216-841-11	METAL CHIP 47K 5%	1/10W
R473	1-216-837-11	METAL CHIP 22K 5%	1/10W
R474	1-216-797-11	METAL CHIP 10 5%	1/10W
R475	1-216-797-11	METAL CHIP 10 5%	1/10W
R476	1-216-864-11	SHORT CHIP 0	
R477	1-216-864-11	SHORT CHIP 0	
R478	1-216-864-11	SHORT CHIP 0	
R479	1-216-864-11	SHORT CHIP 0	
R480	1-216-864-11	SHORT CHIP 0	
R481	1-216-864-11	SHORT CHIP 0	
R482	1-216-845-11	METAL CHIP 100K 5%	1/10W
R483	1-216-845-11	METAL CHIP 100K 5%	1/10W
R494	1-216-837-11	METAL CHIP 22K 5%	1/10W
R495	1-216-853-11	METAL CHIP 470K 5%	1/10W
R801	1-216-821-11	METAL CHIP 1K 5%	1/10W
R802	1-216-829-11	METAL CHIP 4.7K 5%	1/10W
R803	1-216-825-11	METAL CHIP 2.2K 5%	1/10W
R804	1-216-829-11	METAL CHIP 4.7K 5%	1/10W
< SWITCH >			
S801	1-798-044-11	SWITCH, TACTILE (I/Ⓢ)	
< VIBRATOR >			
X401	1-813-202-11	VIBRATOR, CRYSTAL (32kHz)	
X402	1-813-988-21	VIBRATOR, CERAMIC (5.53MHz)	

A-1444-733-A	POWER BOARD, COMPLETE *****		
1-533-233-31	HOLDER, FUSE		
< CAPACITOR >			
C901	1-162-970-11	CERAMIC CHIP 0.01uF 10%	25V
C902	1-162-970-11	CERAMIC CHIP 0.01uF 10%	25V
C903	1-162-970-11	CERAMIC CHIP 0.01uF 10%	25V
C904	1-162-970-11	CERAMIC CHIP 0.01uF 10%	25V
C905	1-107-880-11	ELECT 4700uF 20%	10V
C906	1-162-970-11	CERAMIC CHIP 0.01uF 10%	25V
C907	1-162-970-11	CERAMIC CHIP 0.01uF 10%	25V
C908	1-107-890-11	ELECT 2200uF 20%	25V
C909	1-162-970-11	CERAMIC CHIP 0.01uF 10%	25V
< DIODE >			
D901	8-719-046-47	DIODE 1N5401TM	
D902	8-719-046-47	DIODE 1N5401TM	
D903	8-719-046-47	DIODE 1N5401TM	
D904	8-719-046-47	DIODE 1N5401TM	
D905	6-501-582-01	DIODE 1N4002-B5	
< IC LINK >			
△ PS901	1-533-590-42	LINK, IC (1A)	

Ref. No.	Part No.	Description	Remark
MISCELLANEOUS *****			
△ 64	1-833-786-11	POWER-SUPPLY CORD	
D401	6-502-332-01	LED SDPW31H1C0000 (LCD BACK LIGHT R)	
D402	6-502-332-01	LED SDPW31H1C0000 (LCD BACK LIGHT L)	
△ F901	1-533-451-12	FUSE, GLASS TUBE (DIA. 5) (3.15A/125V)	
LCD401	1-802-620-11	DISPLAY PANEL, LIQUID CRYSTAL	
△ T901	1-445-383-11	TRANSFORMER, POWER	

ACCESSORIES *****			
1-754-102-31	ANTENNA, LOOP (AM)		
1-754-537-11	ANTENNA, DIPOLE (FM)		
3-267-151-01	LID, BATTERY (for RMT-CF1A)		
3-292-622-11	MANUAL, INSTRUCTION (ENGLISH)		
A-1483-895-A	REMOTE COMMANDER (RMT-CF1A)		

MEMO

